

**Tungsten carbide burrs with EDGE cut**  
Defined edges in a one-step operation



**YOU KNOW HOW.  
WE KNOW  
WOW!**



**TRUST BLUE**

- Special design for precise guidance
  - Safe and comfortable to guide
  - Create exact edge shapes in a single step
-

# Tungsten carbide burrs with EDGE cut for defined work on edges

Tungsten carbide burrs for work on edges represent a separate PFERD product line. They are mainly used in steel and aluminium construction and have been specifically designed for chamfering, deburring and rounding of edges. PFERD offers tools for both flexible as well as for defined work on edges.

## Materials that can be worked:

- Steel and cast steel
- Stainless steel (INOX)
- Non-ferrous metals
- Cast iron
- Plastics, other materials

## Matching tool drives:

- Flexible shaft drive
- Straight grinder
- Robot
- Machine tools

## Safety notes:



= Wear eye protection!



= Wear hearing protection!



Wearing protective gloves is recommended. Handle the tool drive with both hands.



Observe the recommended rotational speed, especially when using burrs with long shanks!



## Defined work on edges with the EDGE cut

Tungsten carbide burrs with the EDGE cut have been especially developed for defined work on edges. The special design allows the burr to run directly along the edges without damaging the workpiece. Exact edge shapes can therefore be created in a single step – with either defined chamfers of 30° or 45°, or to a defined radius of 3.0 mm. Among other things, rounding edges is a precautionary measure for anti-corrosion protection according to ISO 12944-3, ISO 8501-3, SOLAS XII/6.3 (Ref. T4/3.01 MSC.1/Circ.1198).

## Advantages:

- Special design for precise guidance.
- Safe and comfortable to guide.
- Create exact edge shapes in a single step.

- Defined chamfering for weld seam preparation for V-shaped seams (60°, ISO 9692-1)
- Defined chamfering for edge breaking (45°)

## Applications:

- Defined work on edges
- Defined deburring
- Breaking and rounding edges in steel and aluminium construction
- Rounding edges in preparation for the application of anti-corrosion coatings in shipbuilding, on crane systems and other steel constructions which are exposed to corrosion loading

## Recommendations for use:

- Use the burrs counterrotationally. In order to produce a fine surface, finally pass them over the edges in the direction of rotation.
- If possible, use EDGE cut burrs with the PFERD compressed-air straight grinder PG 3/210 with matching guide sleeve EFH PG 3/210 (see the info box on page 3).



## PFERDVALUE:

PFERDEFFICIENCY recommends burrs with EDGE cut for long fatigue-free and resource-saving work with perfect results in a very short period of time.



Energy Saving



Time Saving

## EDGE Cutting System (ECS)



The EDGE Cutting System consists of burrs with the EDGE cut and a special guide sleeve that can be positioned on any conventional drive to ensure optimal guidance during light deburring work (see pages 4-5).

## Advantages:

- Improved guidance.
- Can be used with any conventional straight grinder.
- Burr is interchangeable.



# Tungsten carbide burrs with EDGE cut for defined work on edges

## Compressed-air straight grinder PG 3/210 DH and accessories

The combination of this compressed-air straight grinder, the specially designed guide sleeve for this drive and burrs with the EDGE cut, guarantees optimal guidance for creating exact edge shapes.

### Advantages:

- Improved guidance thanks to additional contact surface.
- Exhaust is discharged towards the front, so that the thermal load on the workpiece and the tool is reduced (this is a particular advantage when working with materials which do not conduct heat well, such as stainless steel (INOX)).
- Avoids the build-up of chip deposits when working on aluminium materials.
- Chips are removed in a targeted way by the drive's exhaust air.

### Ordering data:

Compressed-air straight grinder:  
EAN 4007220606315



Guide sleeve: EAN 4007220948897



Guide plate: EAN 4007220967676



## Recommended rotational speed range [RPM]

To determine the recommended cutting speed range [m/min], please proceed as follows:

- 1 Select the material group to be machined.
- 2 Select the cut.
- 3 Establish the cutting speed range.

To determine the recommended rotational speed range [RPM], please proceed as follows:

- 4 Select the required burr diameter.
- 5 The cutting speed range and the burr diameter determine the recommended rotational speed range.



1 Material group		Application	2 Cut	3 Cutting speed
Steel, cast steel	Steels up to 1,200 N/mm <sup>2</sup> (< 38 HRC)	Construction steels, carbon steels, tool steels, non-alloyed steels, case-hardened steels, cast steel, alloyed steels	Work on edges	EDGE 600–900 m/min
	Hardened, heat-treated steels over 1,200 N/mm <sup>2</sup> (> 38 HRC)	Tool steels, tempering steels, alloyed steels, cast steel	Work on edges	
Non-ferrous metals	Soft non-ferrous metals	Soft aluminium alloys	Work on edges	EDGE ALU 900–1.100 m/min
		Brass, copper, zinc	Work on edges	EDGE 600–900 m/min
	Hard non-ferrous metals	Bronze, hard aluminium alloys (high Si content)	Work on edges	EDGE ALU 900–1.100 m/min
		Titanium/titanium alloys	Work on edges	EDGE 250–450 m/min
High-temperature-resistant materials	Nickel-based and cobalt-based alloys (engine and turbine construction)	Work on edges	EDGE 250–450 m/min	
Plastics, other materials	Fibre-reinforced plastics (GRP/CRP), thermoplastics	Work on edges	EDGE ALU 750–1.100 m/min	750–1.100 m/min

### Example:

TC burr,  
EDGE cut,  
burr dia. of 16 mm.  
Machining steels up to 1,200 N/mm<sup>2</sup>.  
Cutting speed: 600–900 m/min

**Rotational speed range:  
12,000–18,000 RPM**

4 Burr dia. [mm]	5 Cutting speeds [m/min]						
	250	350	450	600	750	900	1,100
Rotational speeds [RPM]							
3	27,000	37,000	48,000	64,000	80,000	95,000	117,000
6	13,000	19,000	24,000	32,000	40,000	48,000	59,000
8	10,000	14,000	18,000	24,000	30,000	36,000	44,000
10	8,000	11,000	14,000	19,000	24,000	29,000	35,000
12	7,000	9,000	12,000	16,000	20,000	24,000	30,000
13	6,000	9,000	11,000	15,000	18,000	22,000	27,000
16	5,000	7,000	9,000	12,000	15,000	18,000	22,000

# Tungsten carbide burrs with EDGE cut

## for defined work on edges

### Conical counterbore shape KSJ EDGE

Conical counterbore burr for the production of precisely defined chamfers. Suitable for counterboring and chamfering of defined 30° chamfer angles.

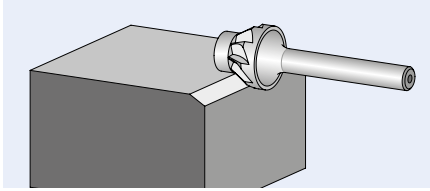



**Ordering notes:**

- Please complete the description with the desired cut.

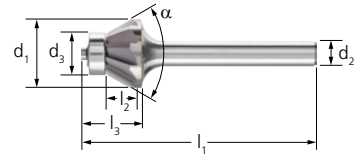
**PFERDVALUE:**



d <sub>1</sub> [mm]	l <sub>2</sub> [mm]	d <sub>2</sub> [mm]	l <sub>1</sub> [mm]	d <sub>3</sub> [mm]	l <sub>3</sub> [mm]	α	Cut		Description
							EDGE	EDGE ALU	
							 		
							EAN 4007220		

**Shank dia. 6 mm**

16	5	6	54	10	14	60°	952443	098011	1	KSJ 1605/6 ... 30°
----	---	---	----	----	----	-----	--------	--------	---	--------------------

### Conical counterbore shape KSK EDGE

Conical counterbore burr for the production of precisely defined chamfers. Suitable for counterboring and chamfering of defined 45° chamfer angles. The chamfers created using the EDGE Cutting System (ECS) are 1.2 mm (+/- 0.2 mm) wide.

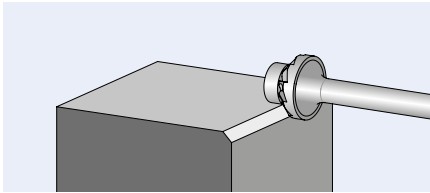



**Ordering notes:**

- The EDGE Cutting System (ECS) burr can be reordered and replaced if required. Matching burr: KSK 1603/6 EDGE ALU 45°.
- Please complete the description with the desired cut.

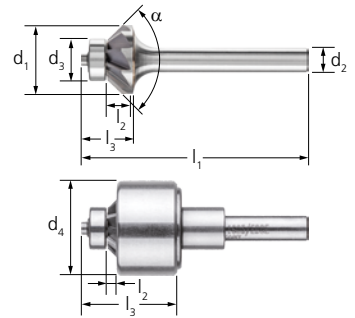
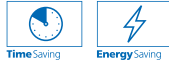
**PFERDVALUE:**



d <sub>1</sub> [mm]	l <sub>2</sub> [mm]	d <sub>2</sub> [mm]	l <sub>1</sub> [mm]	d <sub>3</sub> [mm]	l <sub>3</sub> [mm]	d <sub>4</sub> [mm]	α	Cut		Description
								EDGE	EDGE ALU	
							 			
							EAN 4007220			

**Shank dia. 6 mm**

16	3	6	52	10	12	-	90°	952436	098004	1	KSK 1603/6 ... 45°
	1	6	52	10	24	25	90°	097984	097991	1	KSK 1603/6 ... 45° ECS



# Tungsten carbide burrs with EDGE cut

## for defined work on edges

### Concave radius burrs V EDGE

Concave radius burrs for the production of precise radii. Cannot be re-sharpened. Suitable for the production and processing of 3 mm outer radii.

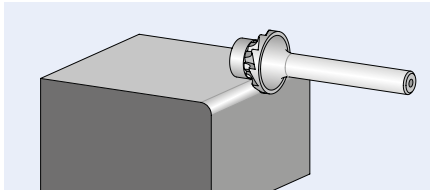



#### Ordering notes:

- The EDGE Cutting System (ECS) burr can be reordered and replaced if required. Matching burr: V 1612/6 EDGE R3,0.

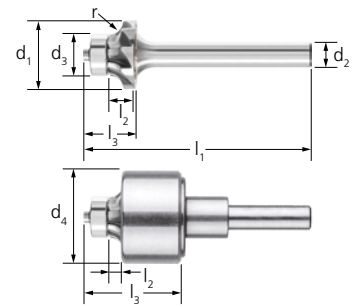
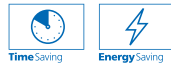
#### PFERDVALUE:



d <sub>1</sub> [mm]	l <sub>2</sub> [mm]	d <sub>2</sub> [mm]	l <sub>1</sub> [mm]	d <sub>3</sub> [mm]	l <sub>3</sub> [mm]	d <sub>4</sub> [mm]	r [mm]	Cut EDGE 		Description
								EAN 4007220		

#### Shank dia. 6 mm

16	3	6	52	10	12	-	3.0	952412	1	V 1612/6 EDGE R3,0
					24	25	3.0	098028	1	V 1612/6 EDGE R3,0 ECS

